



# USEA SAFETY INITIATIVES

RESEARCH. EDUCATION. IMPLEMENTAION



## RESEARCH

Dan Michaels Jump Latch is finalizing testing and development by a dedicated task force to move it forward for FEI approval.

Safety Equipment Research is being organized in partnership with Virginia Tech Labs to test and evaluate the use of safety vests and air vests.

Equine Welfare and Safety remains a top priority as the subcommittee analyzes historical horse fall data to identify risk factors associated with cross-country falls.

Information is also being gathered to formulate guidelines for equine competition during extreme environmental conditions.



# EDUCATION

USEA Safety Committees are working with the Eventing Coaches Program and Eventing Licensed Officials Committee to produce educational resources for the membership.



## Improving Skills

ECP Handbook was updated to clarify the purpose of each level of competition and the rider skills necessary to be successful at progressing skills

## Fall Safety

Educational materials are being prepared for distribution to inform members of the importance of fall safety to reduce injury

## Managing Potential Risks

- USEF Revamped the Watch List to improve efficacy
- ERQI Report distribution policies were updated to supply more officials with the information prior to events

# FRANGIBLE TECHNOLOGY

Efforts continue to look at the impacts the available technology is having at reducing risk of horse and rider falls.

USEF Foundation allotted \$150,000 for 2024 to continue supporting the distribution of grants for events to construct frangible fences.

Eventing rules have been updated based on reviewed fall data to ensure that whenever possible obstacles are constructed with frangible technology for the Training level and above.



## Dan Michaels Jump Latch

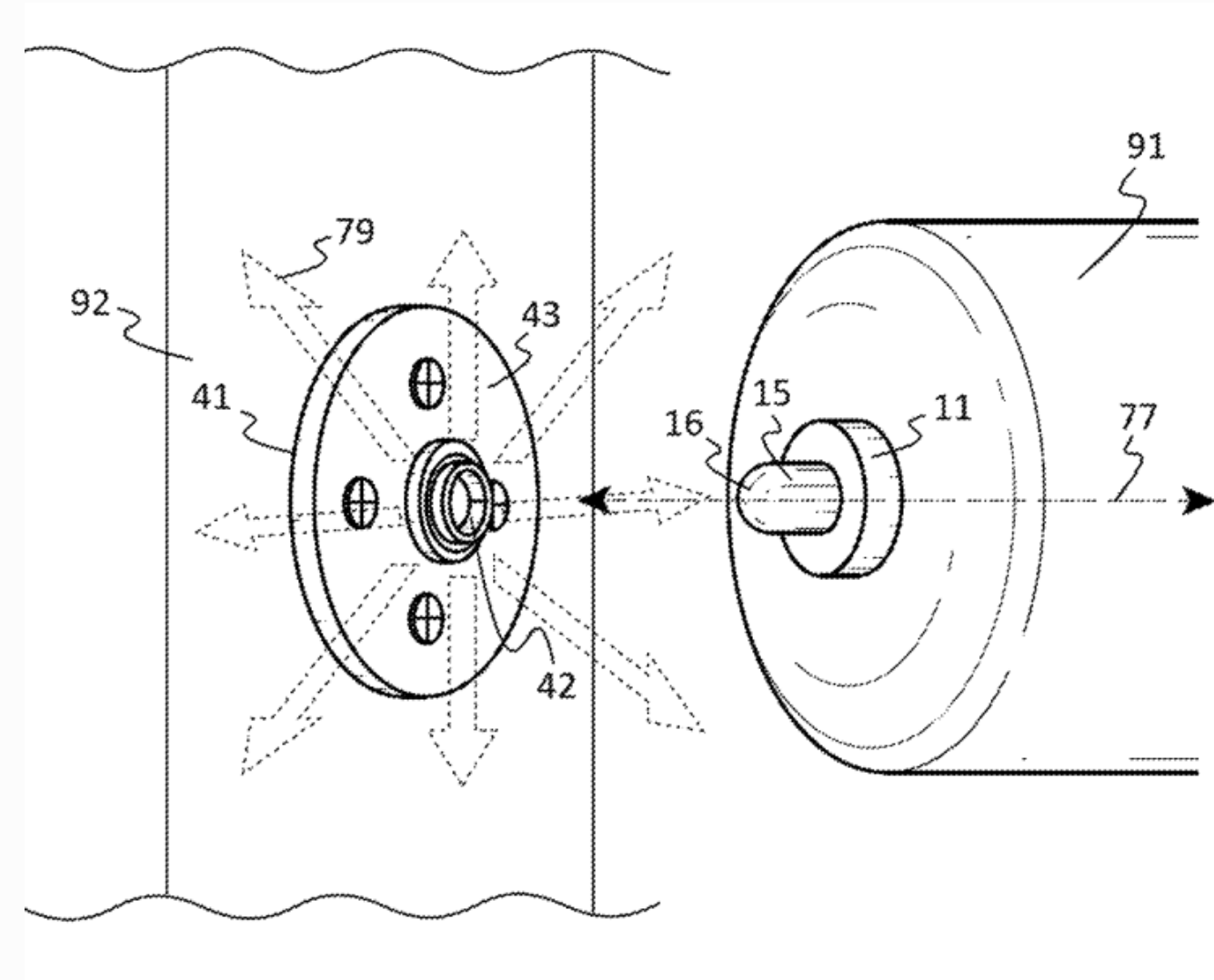
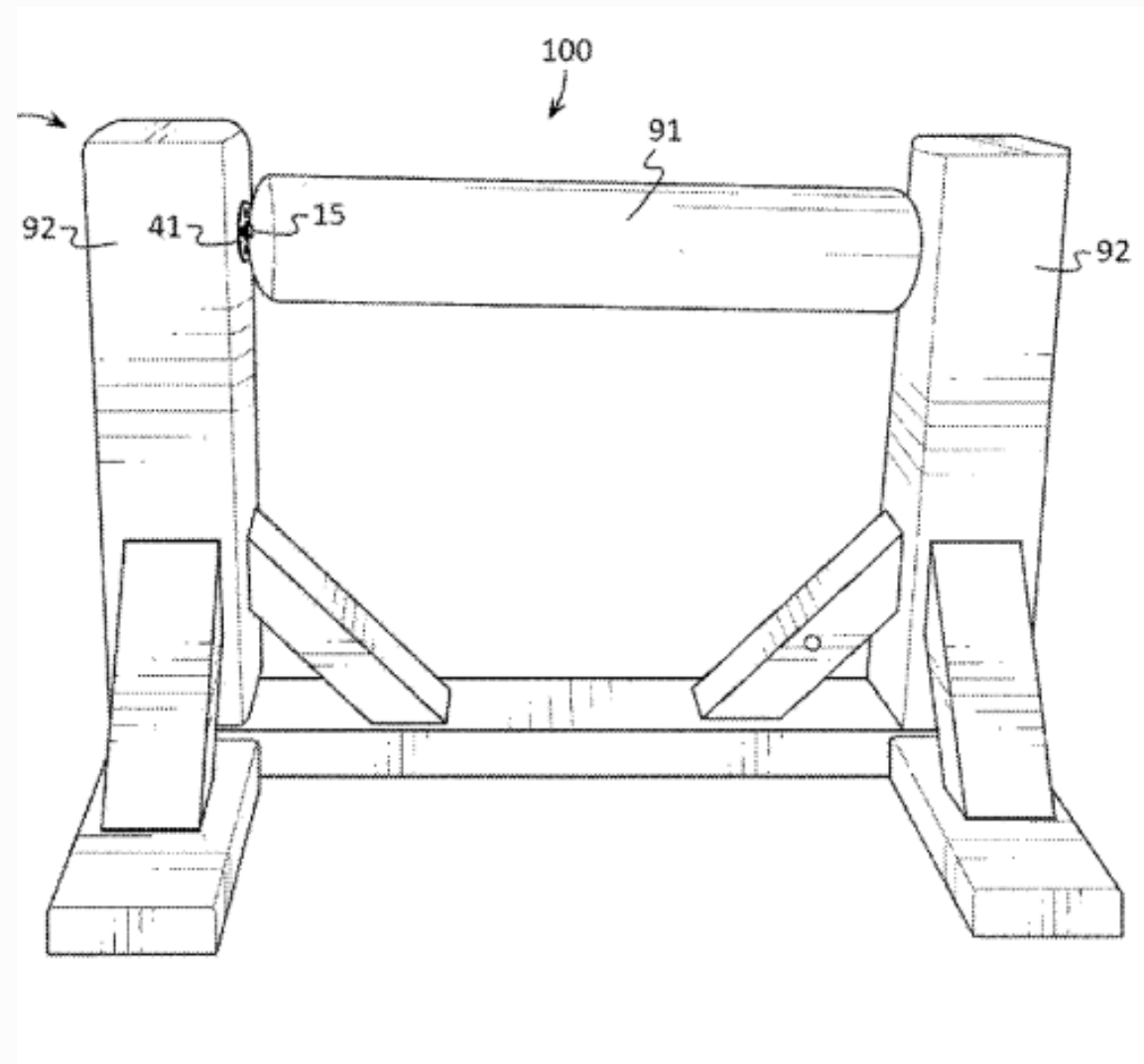

USEA holds the patent for the device and looks forward to the work of the testing task force to finalize the FEI approval process.





# QUALIFICATIONS

Minimum Eligibility Requirements (MER) to qualify for a move up have been updated based on horse and rider fall data to improve the safety of the sport. MER scores are now aligned with the FEI score requirements.

- not more than 45 penalty points in the Dressage test
- no jumping penalties during the Cross Country test unless, and no more than 75 seconds exceeding optimal time
- not more than 16 penalties at obstacles in the Jumping test

The new qualifications require two additional MERs for the rider and 4 MERs for the horse. New for Preliminary, Intermediate, and Advanced, one MER must be obtained as a combination, unless the rider has more than 10 MERs at the level the combination requirement is waived.

Modified level competitors must obtain an MER at two horse trials at the Training level or higher.