

mimSAFE

www.mimsafe.se

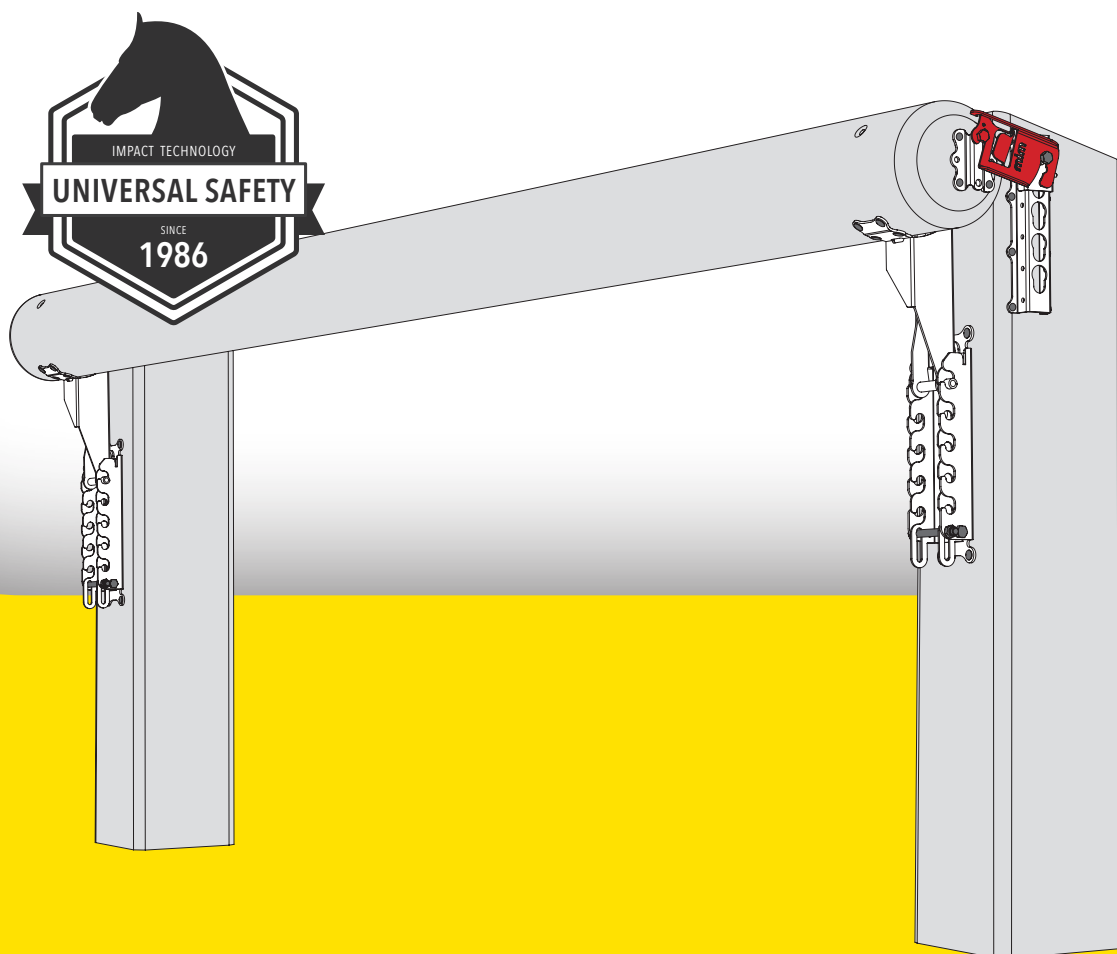

ASSEMBLY INSTRUCTIONS

ADJUSTABLE POST & RAIL KIT

NEWERA USIT SYSTEM





APPROVED

INFORMATION ABOUT THE ADJUSTABLE POST & RAIL KIT

The Adjustable Post & Rail Kit has been designed and developed specifically to greatly reduce the risk of rotational falls. The most important element of this kit is that it will not break the fence or

risk injury to the horse if hit vertically. The rail is only released when impacted horizontally by the horse. The risk of a resulting rotational fall is thus reduced.

RECOMMENDED FENCE DIMENSIONS									
POST	RAIL								
									
MIN-MAX SIZE	MIN-MAX DIAMETER								
<table border="1"><tr><td>6 - 10</td><td>inch</td></tr><tr><td>150 - 250</td><td>mm</td></tr></table>	6 - 10	inch	150 - 250	mm	<table border="1"><tr><td>8 - 12</td><td>inch</td></tr><tr><td>200 - 300</td><td>mm</td></tr></table>	8 - 12	inch	200 - 300	mm
6 - 10	inch								
150 - 250	mm								
8 - 12	inch								
200 - 300	mm								
	MAXIMUM LENGTH								
MIN-MAX SIZE	<table border="1"><tr><td>16.4</td><td>ft</td></tr><tr><td>500</td><td>cm</td></tr></table>	16.4	ft	500	cm				
16.4	ft								
500	cm								
<table border="1"><tr><td>6 - 10</td><td>inch</td></tr><tr><td>150 - 250</td><td>mm</td></tr></table>	6 - 10	inch	150 - 250	mm	MAXIMUM WEIGHT				
6 - 10	inch								
150 - 250	mm								
	<table border="1"><tr><td>440.92</td><td>lb</td></tr><tr><td>200</td><td>kg</td></tr></table>	440.92	lb	200	kg				
440.92	lb								
200	kg								



It is essential to follow the recommended dimensions on the fence for the correct function. If the recommended procedure is not correctly followed it may cause the failure of the device.

For your own safety and that of others please note the following step by step advice for correct preparation and installation. It is important that you follow your own health and safety requirements when constructing this kit.

Ensure that you have all parts of the Adjustable Post & Rail Kit.

Be aware of the risk of injury when handling heavy rails, poles and the tools for mounting.

WARNING!

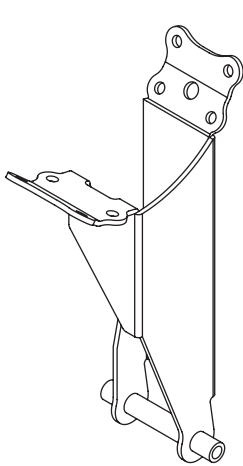
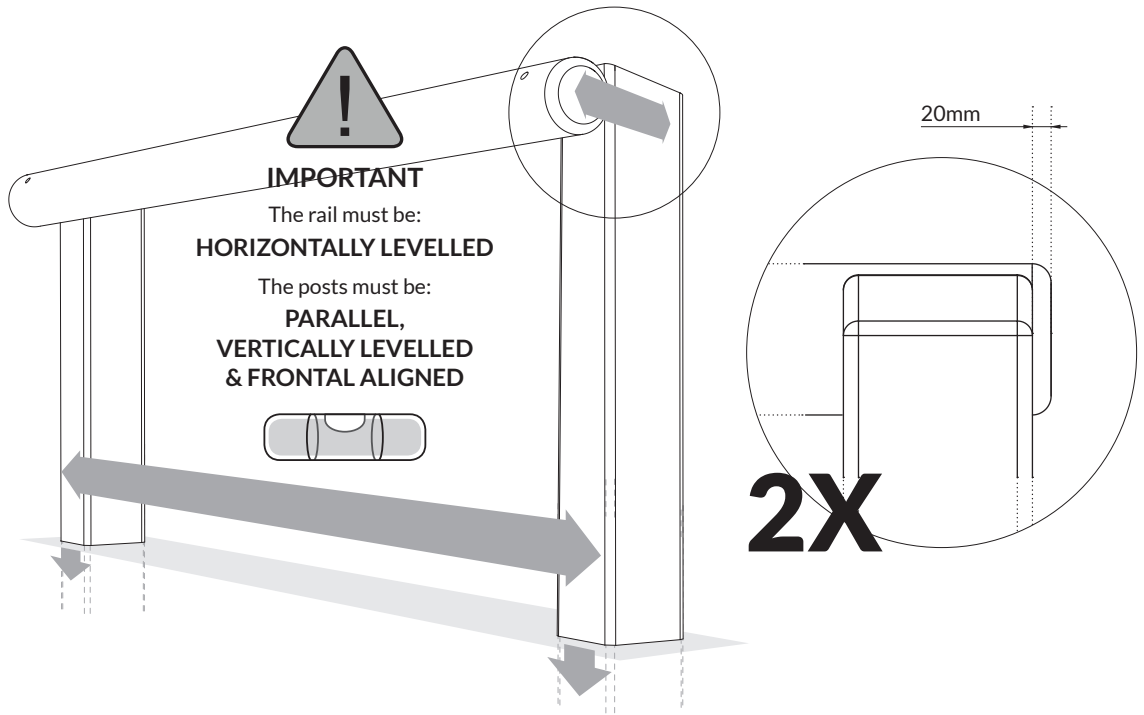

A FS65B
Part no 2x

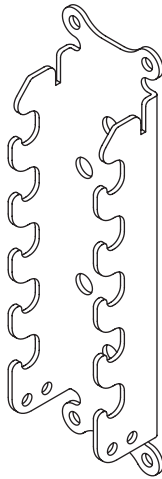

B F65E
Part no 2x

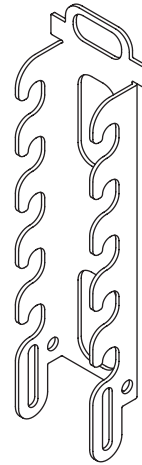

C F65F
Part no 2x

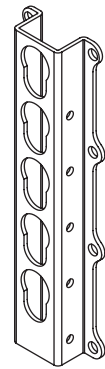

D F65H
Part no 2x

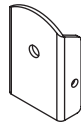









E F65G
Part no 2x



F F70A
Part no 2x

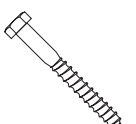

G F18C
Part no 6x

M-SM6x70 2X 	M-MM6Ny 2X 	M-SM10x30 2X 	M-MM10Ny 2X 	M-BR11x22x2s 4X 	M-BR11x28x2s 2X 	M-SM10x100 2X 	M-MM10Ny 4X 	M-TS10X90 2X 
---	--	--	---	---	---	--	---	--

STEP
1

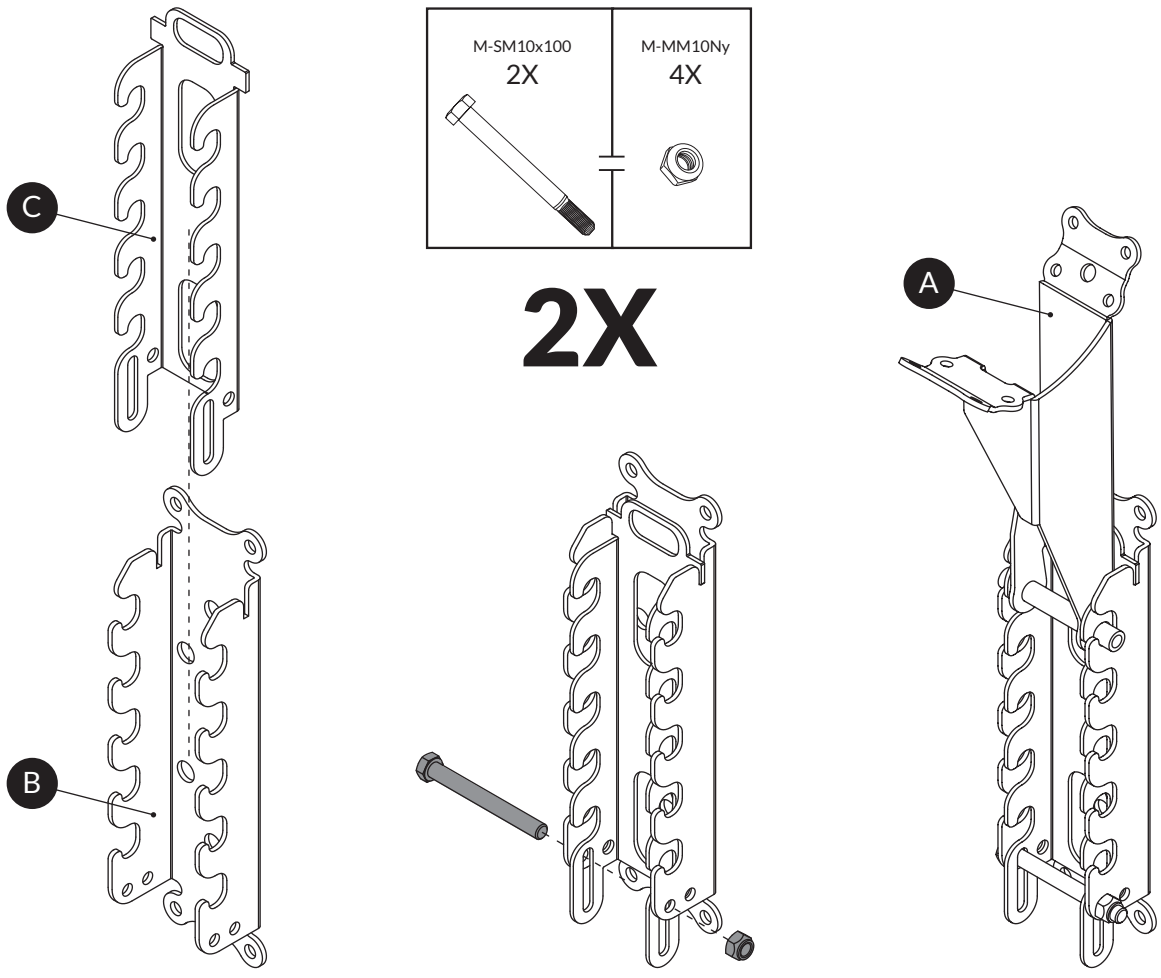

STEP
2

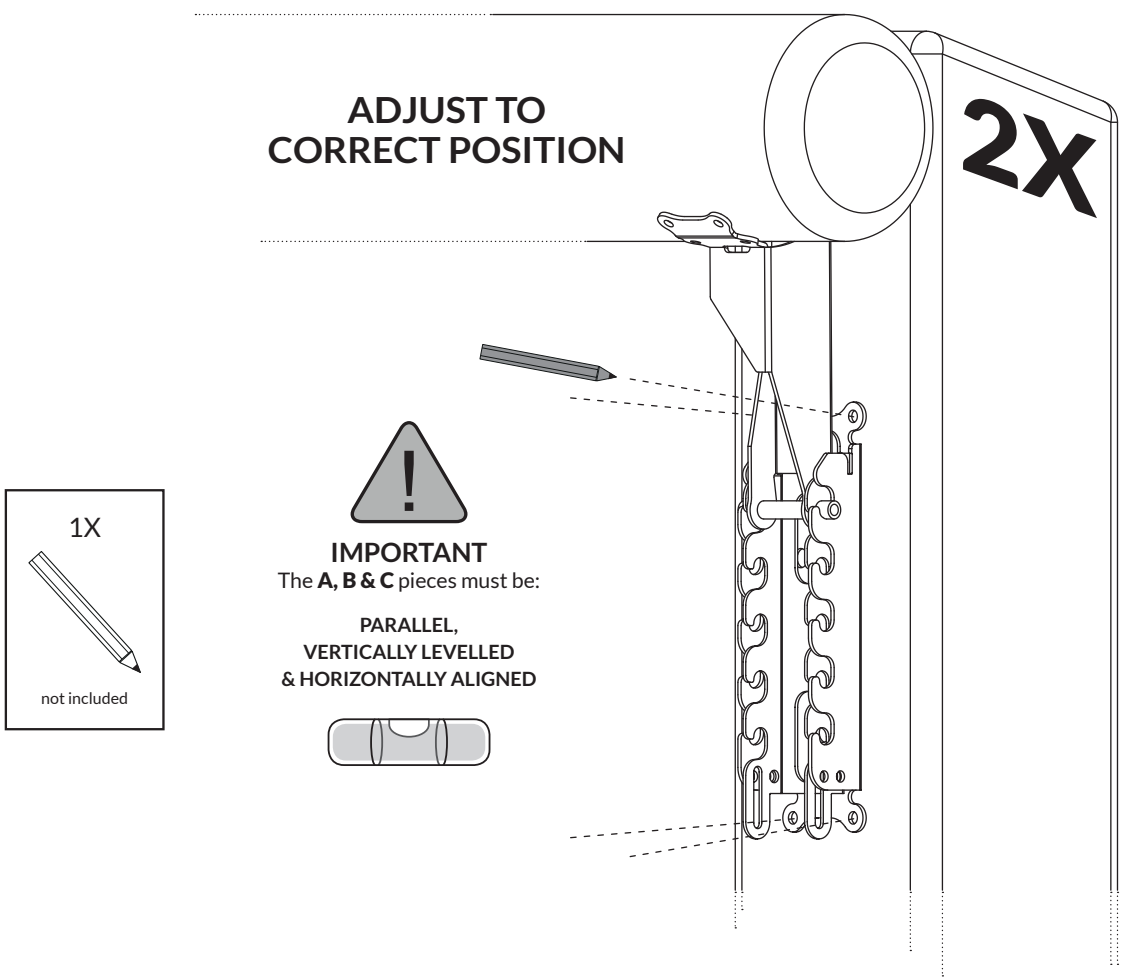

STEP
3

2X

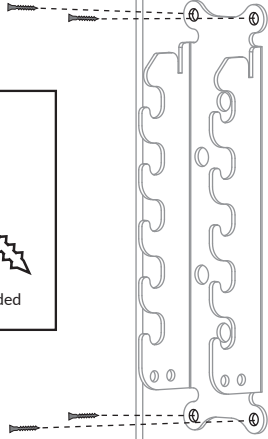
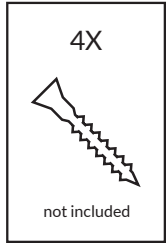

STEP
3*

*alternative

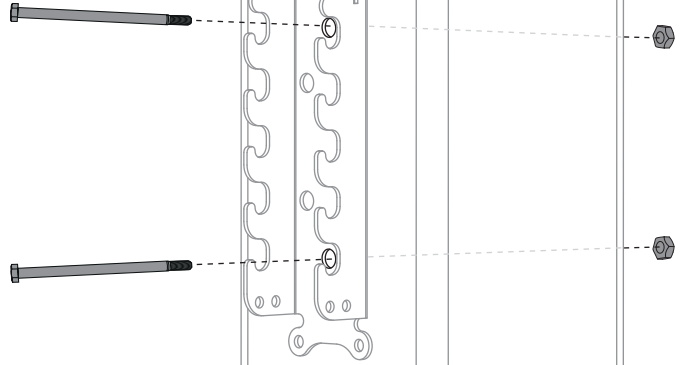
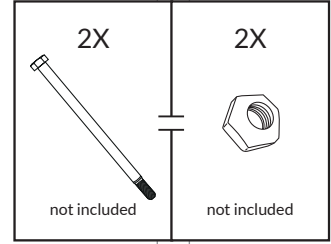

2X

STEP
4

2X

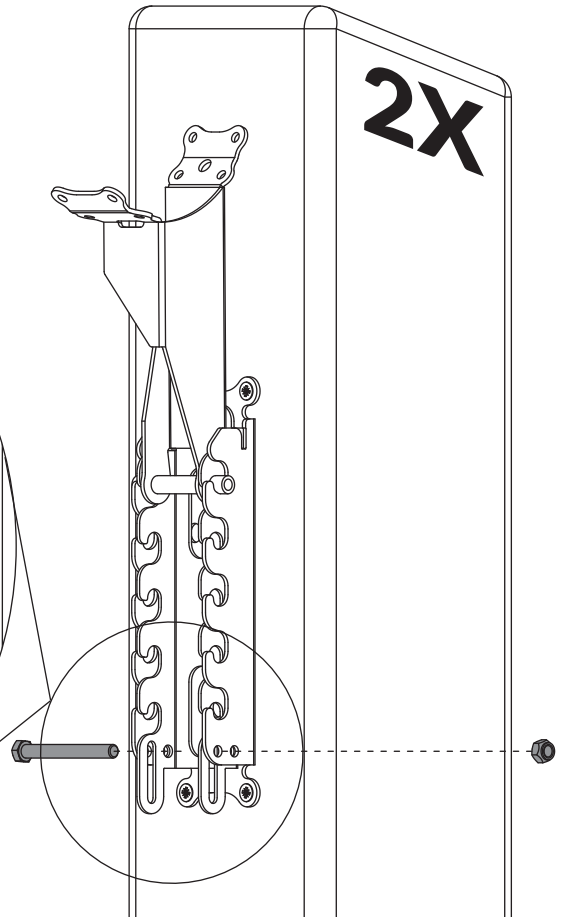
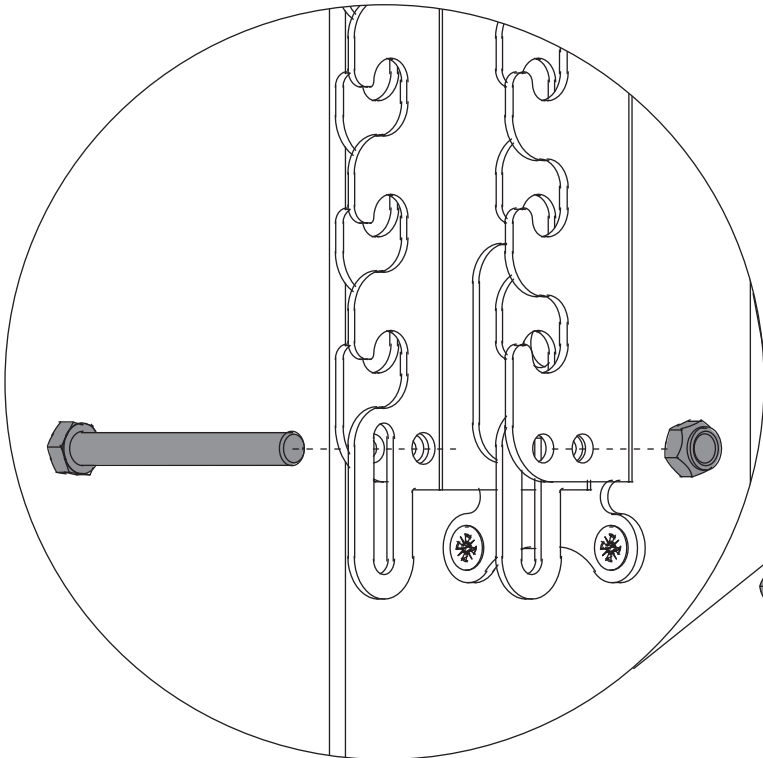

STEP
5

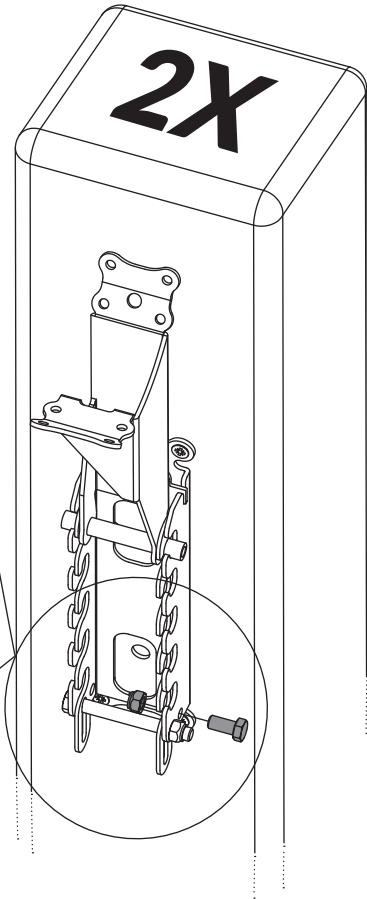
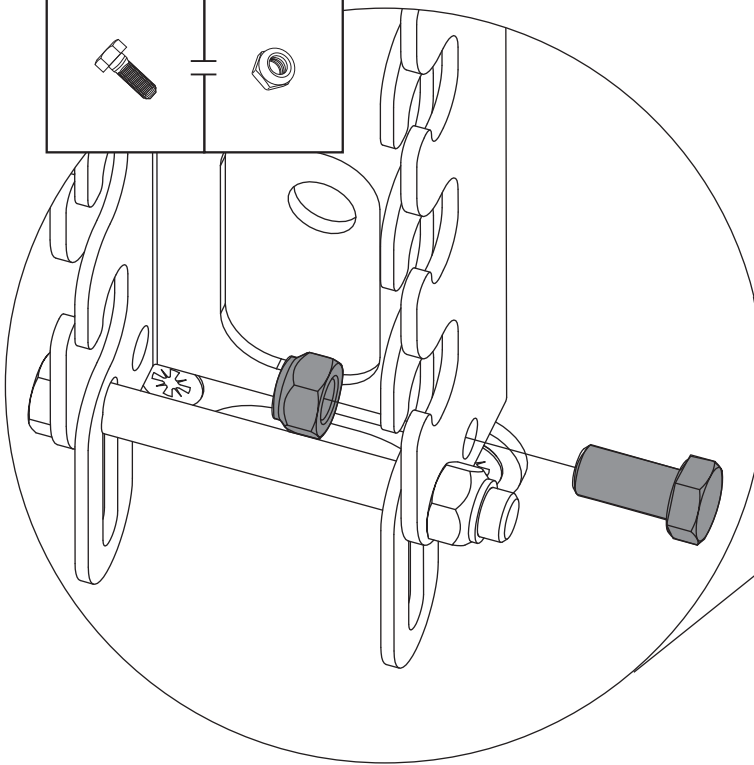
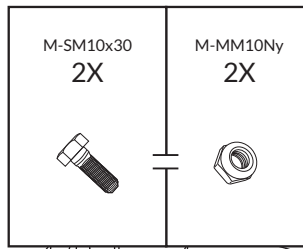

STEP
6

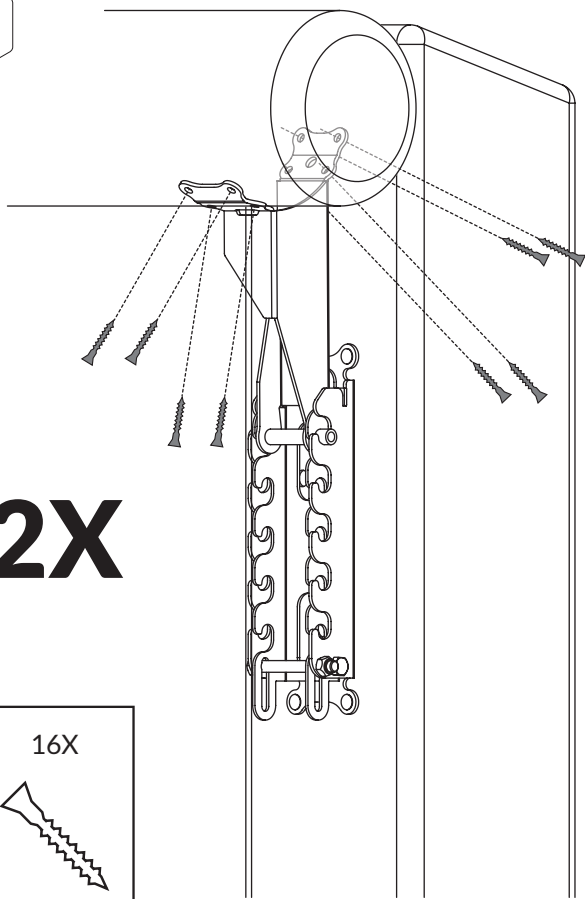

2X

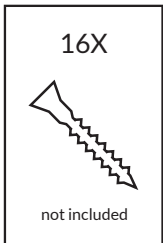

STEP
6*

*alternative

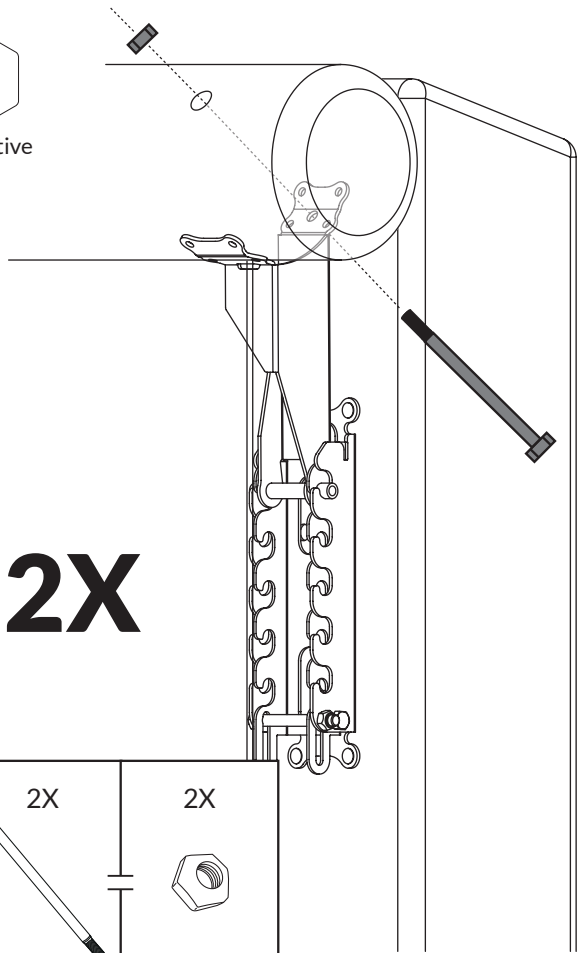

2X

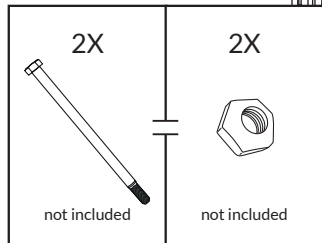

STEP
7

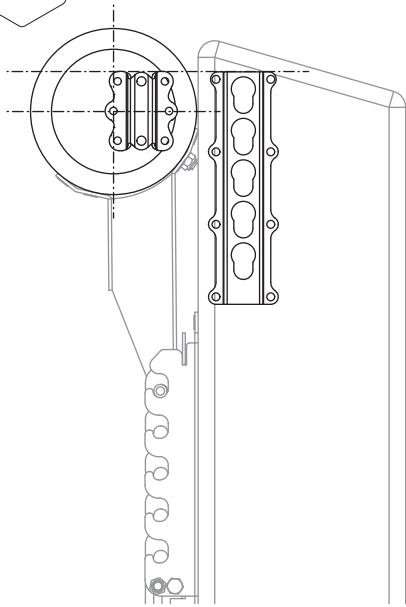

2X

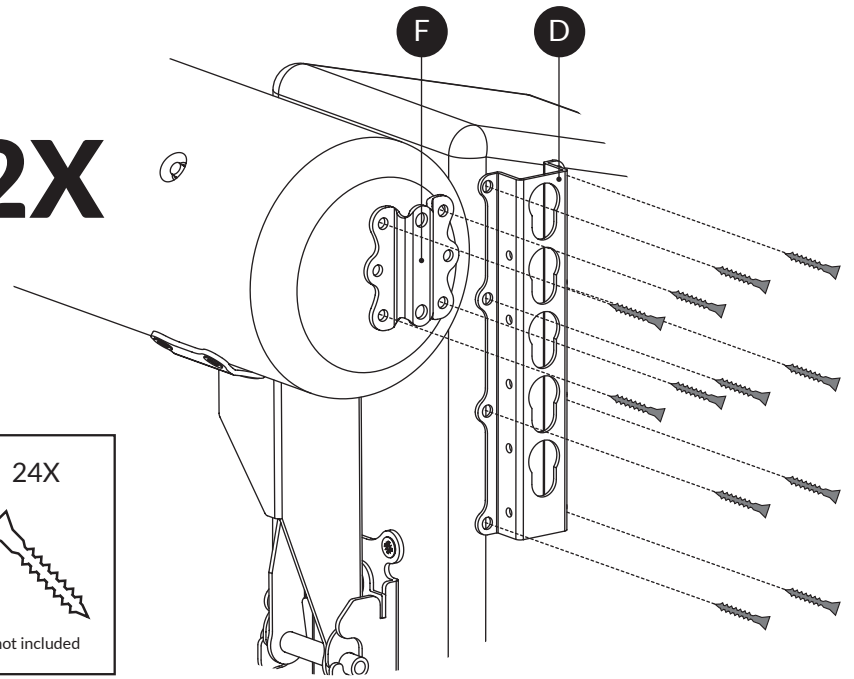
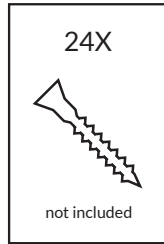

STEP
8



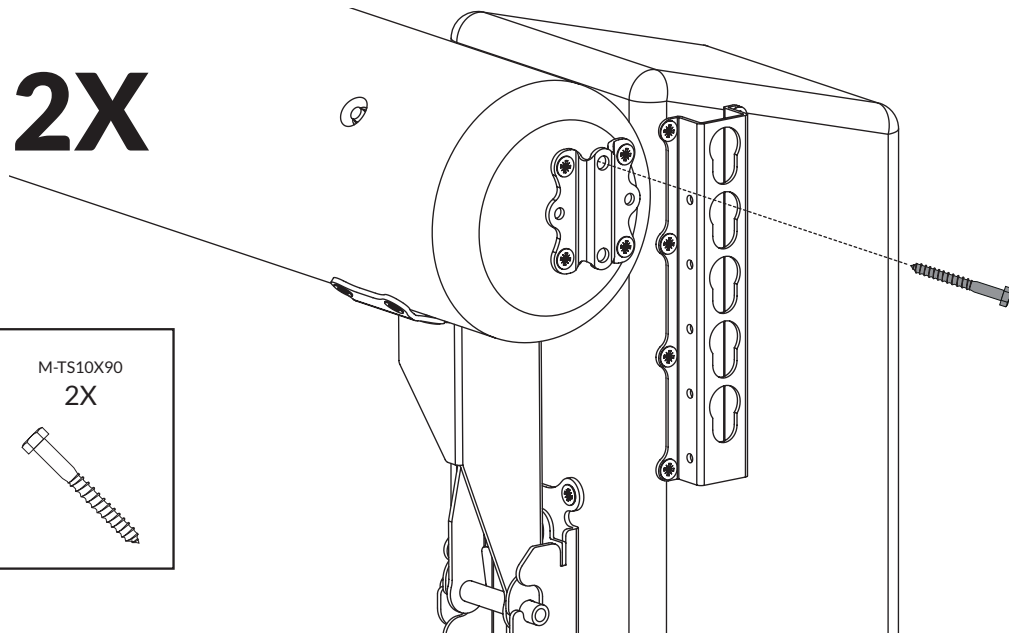
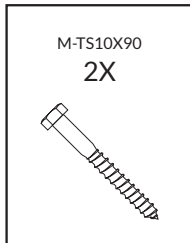

2X

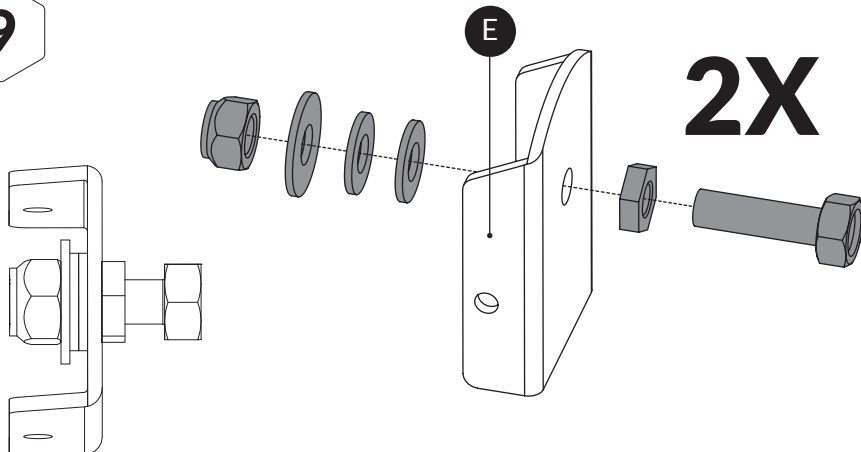

STEP
9

2X



M-SM10x30 2X 	M-BR11x28x2s 2X 	
M-MM10Ny 2X 	M-BR11x22x2s 4X 	M-MM10Ny 2X 

STEP
10

2X

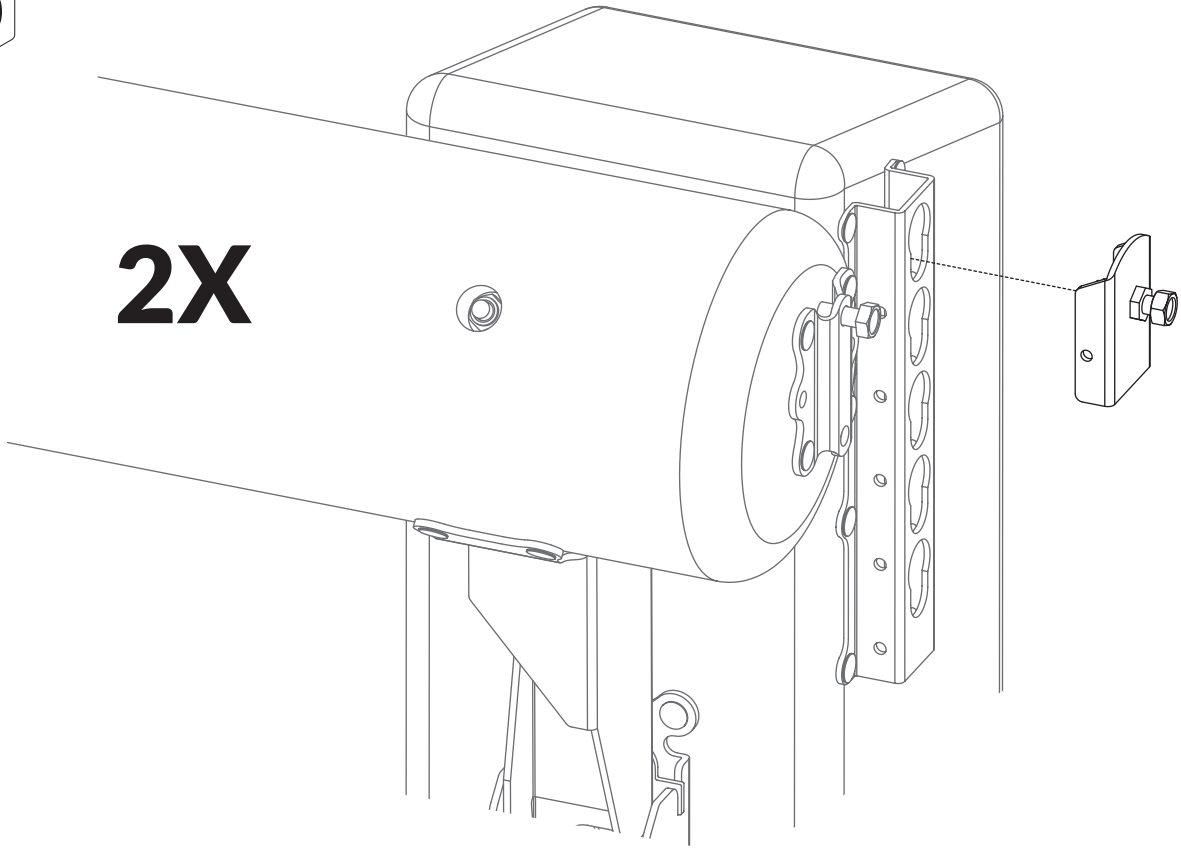

STEP
11

2X

M-SM6x70 2X	M-MM6Ny 2X

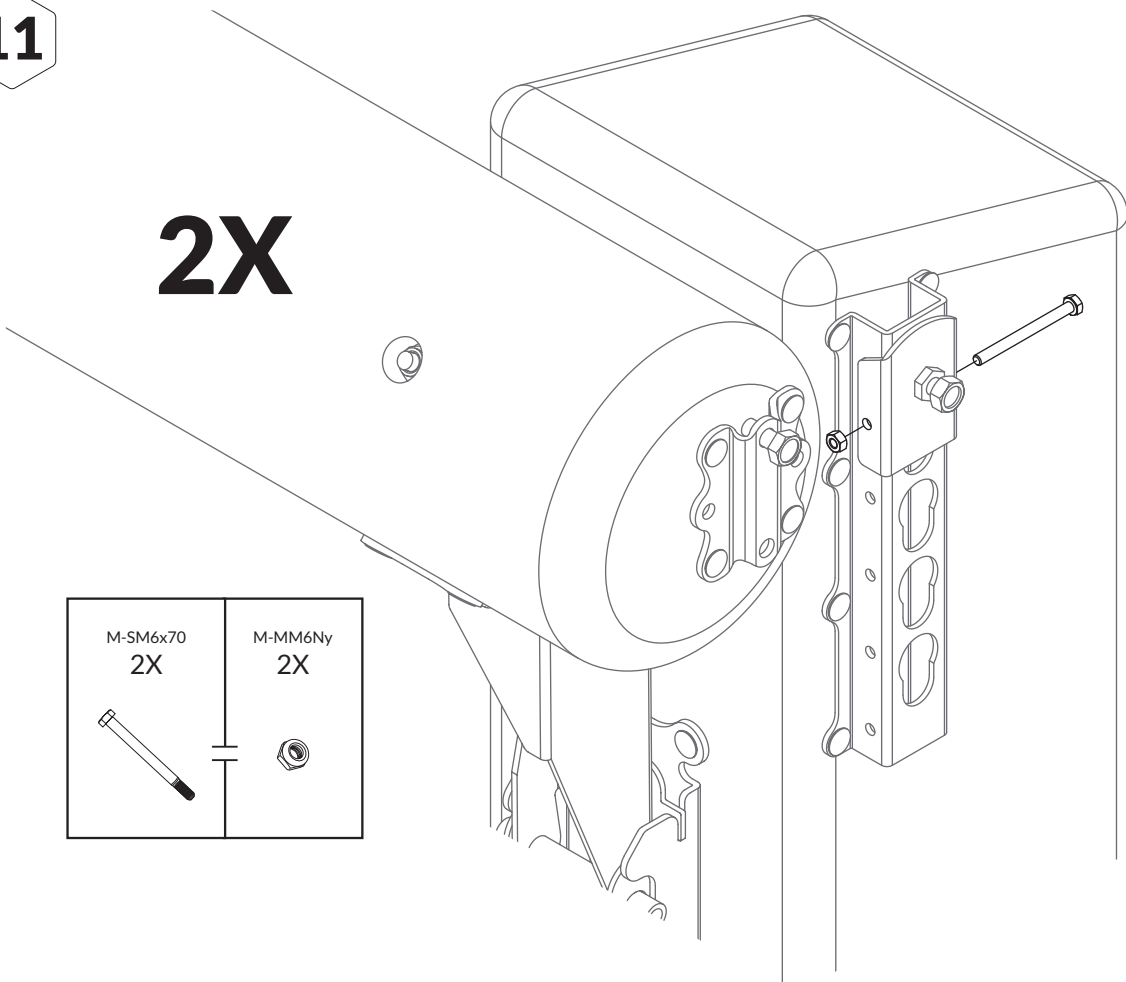

STEP
12

2X

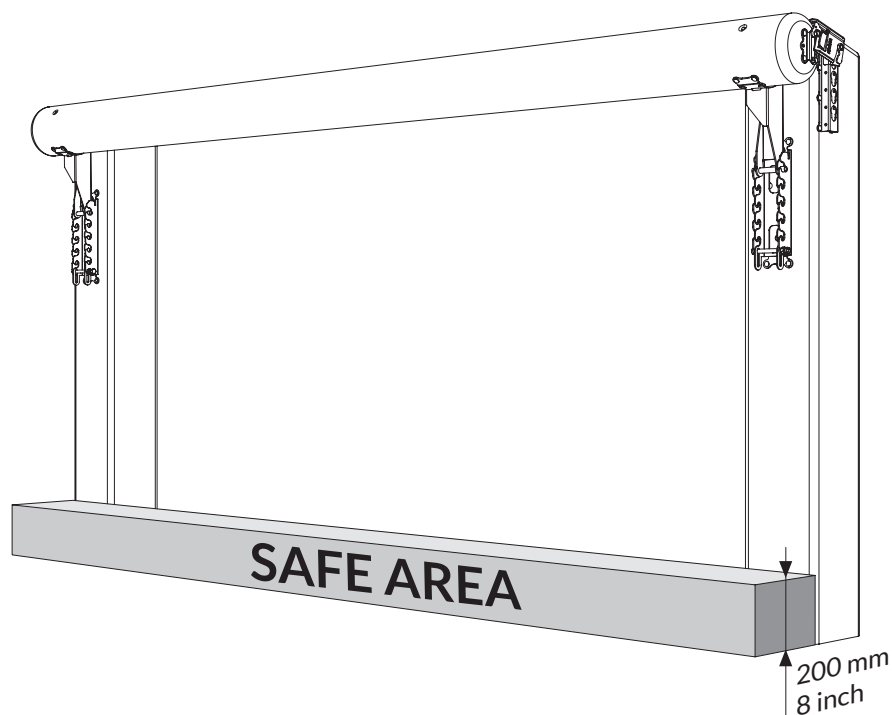
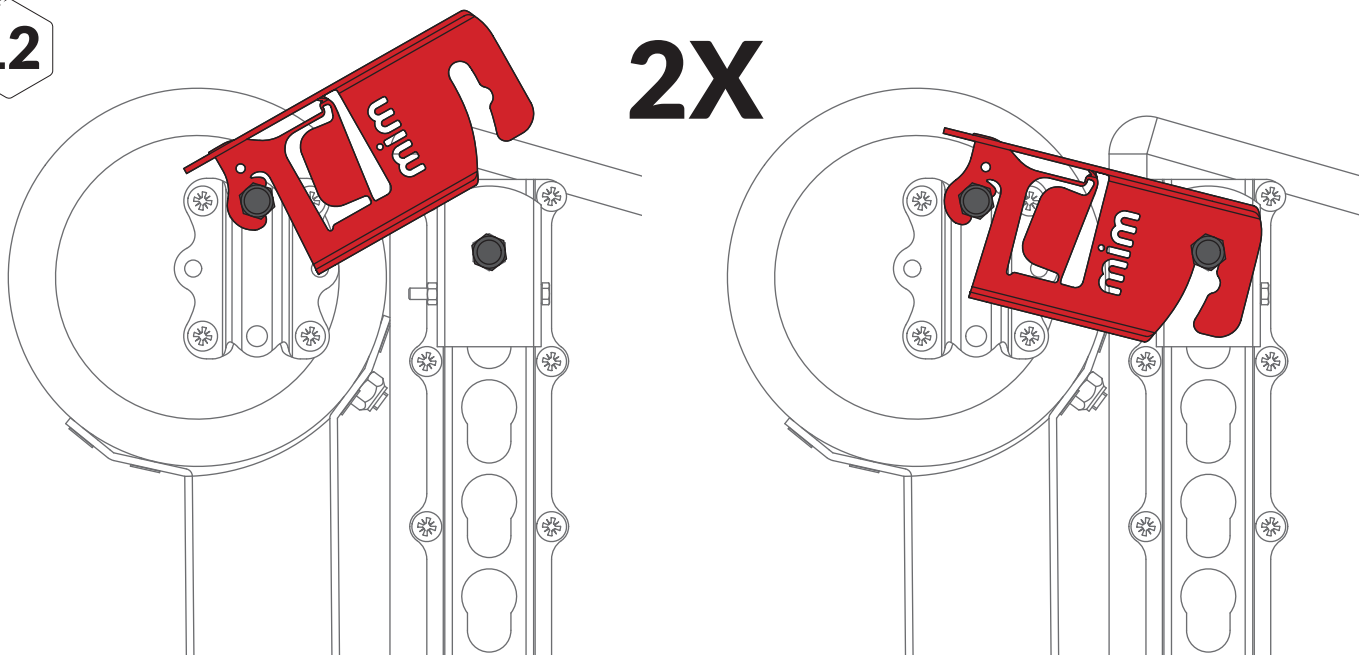

The advantages of the Adjustable Post & Rail Kit

1. It has been produced with safety being the first and foremost important factor.
2. Reduces the possibility of rotational falls.
3. FEI approved number FEI01SWE.
4. Controlled movement of fence during release.
5. Reconstruction time is less than 30 seconds.
6. The parts are made of powder coated steel and can be left outside, no maintenance is required.
7. The very highest quality of product from Sweden.

The Mim clip (F18C) breaks on impact, which clearly indicates when replacement is needed. The rail is connected to the post with a hinge that makes the fence easy to reconstruct. This saves time, guarantees fair and correct judging for riders and contributes to the overall safety of the sport.